



True Union Utility Swing & Spring Check Valves



Features - PVC White & PVC Clear

Spears® True Union Utility Swing Check and spring assisted True Union Utility Spring Check Valves offer a compact, high performance check valve for Landscape & Irrigation, Pool & Spa, Aquaculture, OEM 1 and many general purpose applications. True Union design allows for easy in-line replacement of maintenance free sealed units. These valves feature long-life EPDM elastomer seats with weighted disc for full-flow with minimal restriction and positive shutoff. Spring assisted "Spring Check" model incorporates a positive-pressure spring to assist in valve closing without slamming. Produced from PVC White or PVC Clear material with Socket, Threaded or SR Threaded end connectors in IPS Sizes 1/2" through 4".

Sample Engineering Specification

All thermoplastic check valves shall be True Union Utility Swing Check or True Union Utility Spring Check type constructed from PVC Type I, ASTM D 1784 Cell Classification 12454. All union nuts shall have Buttress threads coupled to a replaceable sealed unit with EPDM seat and weighted disc. All Spring Check Valves shall have stainless steel spring assisted operation. All valves shall have external flow arrow direction designation. All valves shall be certified by NSF International for use in potable water service. All valves shall be pressure rated to 150 psi for water @ 73°F in full flow (open) position and to 75 psi @ 73°F back pressure (closed), as manufactured by Spears® Manufacturing Company.

- Chemical & Corrosion Resistant PVC White or High Visibility PVC Clear Construction
- No Metal Parts on Swing Check - Stainless Steel Spring on Spring Check
- True Union style for Easy In-line Replacement of Sealed Unit
- Strong Buttress Threaded Union Nuts
- Engineered for Maximum Flow, Quick Response & Positive Shutoff
- Long-Life, High Grade EPDM Seat with Weighted Disc
- Spring Assisted Spring Check Model Option for Positive Closing
- Pressure Rated to 150 psi @ 73°F Full-Flow (open) and 75 psi @ 73°F Back Pressure (closed)
- Suitable for either Horizontal or Vertical Up-flow Installations and Vacuum Service
- NSF® Certified for Potable Water Use
- Silicone-Free Assembly

Quick-View True Union Utility Swing Check Valve Selection Chart

Valve Size	Seat Material	PVC Material ¹			Pressure Rating
		Socket	Threaded	SR Threaded	
1/2	EPDM	S1720-05	S1720-05F	S1720-05FSR	150 psi @ 73°F Full Flow (Open)
3/4	EPDM	S1720-07	S1720-07F	S1720-07FSR	
1	EPDM	S1720-10	S1720-10F	S1720-10FSR	
1-1/4	EPDM	S1720-12	S1720-12F	S1720-12FSR	
1-1/2	EPDM	S1720-15	S1720-15F	S1720-15FSR	75 psi Back Pressure (Closed)
2	EPDM	S1720-20	S1720-20F	S1720-20FSR	
2-1/2	EPDM	S1720-25	S1720-25F	S1720-25FSR	
3	EPDM	S1720-30	S1720-30F	S1720-30FSR	
4	EPDM	S1720-40	S1720-40F	S1720-40FSR	

1: For PVC Clear Swing Check, replace dash (-) separator with the letter "C" in the part number (e.g. S1720C05), (e.g. S1720C05F) or (e.g. S1720C05FSR)

Quick-View True Union Utility Spring Check Valve Selection Chart

Valve Size	Seat Material	PVC Material ¹			Pressure Rating
		Socket	Threaded	SR Threaded	
1/2	EPDM	S1780-05	S1780-05F	S1780-05FSR	150 psi @ 73°F Full Flow (Open)
3/4	EPDM	S1780-07	S1780-07F	S1780-07FSR	
1	EPDM	S1780-10	S1780-10F	S1780-10FSR	
1-1/4	EPDM	S1780-12	S1780-12F	S1780-12FSR	
1-1/2	EPDM	S1780-15	S1780-15F	S1780-15FSR	75 psi Back Pressure (Closed)
2	EPDM	S1780-20	S1780-20F	S1780-20FSR	
2-1/2	EPDM	S1780-25	S1780-25F	S1780-25FSR	
3	EPDM	S1780-30	S1780-30F	S1780-30FSR	
4	EPDM	S1780-40	S1780-40F	S1780-40FSR	

1: For PVC Clear Spring Check, replace dash (-) separator with the letter "C" in the part number (e.g. S1780C05), (e.g. S1780C05F) or (e.g. S1780C05FSR)

Valves Technical
True Union Utility Swing & Spring Check Valves



True Union Utility Swing Check Valve

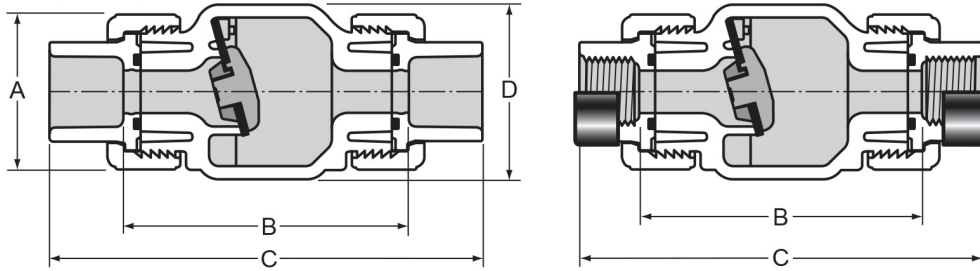

True Union Utility Spring Check Valve

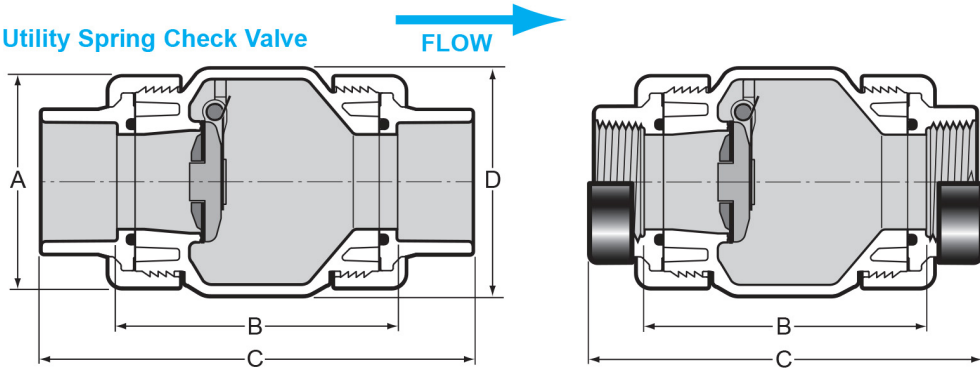

Dimensions

Nominal Size	A	Dimension Reference (inches, ± 1/16)				D	
		B		C		Swing	Spring
		Socket	Threaded/SR Threaded	Socket	Threaded/SR Threaded		
1/2	1-7/8	3-7/16	3-1/2	5-3/16	4-13/16	2-1/8	2-5/8
3/4	2-1/4	3-9/16	3-9/16	5-1/2	4-15/16	2-1/8	2-5/8
1	2-9/16	4-1/8	4-5/16	6-7/16	6	2-5/8	2-5/8
1-1/4	3-1/8	4-7/8	5-1/16	7-7/16	6-13/16	3-3/8	3-3/8
1-1/2	3-9/16	4-9/16	4-3/4	7-3/8	6-1/2	3-3/8	3-3/8
2	4-5/16	5-5/8	5-3/4	8-5/8	7-9/16	4-1/4	4-1/4
2-1/2	6-3/16	7-7/16	7-9/16	10-15/16	10-3/16	5-11/16	5-11/16
3	6-13/16	7-7/16	7-1/2	11-3/16	10-1/4	5-11/16	5-11/16
4	7-3/4	9-3/4	9-7/8	14-5/16	12-3/4	7-1/4	7-1/4

General Installation Information: True Union Swing Check valves are designed for horizontal installations, but may be installed in up-flow only vertical position. Check valves **MUST** be installed with the valves **FLOW** arrow pointing in the direction of the flow. Do not install valve upside down. Flow velocity should not exceed 5ft./sec. Minimum opening pressure less than 0.5 psi.

Temperature Pressure Rating

System Operating Temperature °F (°C)			100 (38)	110 (43)	120 (49)	130 (54)	140 (60)	150 (66)	160 (71)	170 (77)	180 (82)	190 (88)	200 (93)	210 (99)
Valve Pressure Rating psi (MPa)	1/2" - 4"	PVC	150 (1.03)	135 (.93)	110 (.76)	75 (.52)	50 (.34)	-0- (-0-)	-0- (-0-)	-0- (-0-)	-0- (-0-)	-0- (-0-)	-0- (-0-)	-0- (-0-)