



# Schedule 80 PVC Technical Installation Instructions

## Basic Installation

Hot-Tap Saddles are designed for adding branch connections to piping systems under live ("hot") pressure. Hot-Tap Saddle branch outlets are either 3/4" socket (with 1" Spigot O.D.) or 1-1/2" socket (with 2" Spigot O.D.) in saddle sizes 2" through 8" to fit IPS pipe using a built-in O-ring seal. Internal cutter is operated using conventional ratchet and drive extension and permanently retains coupon cut from pipe. Maximum operating pressure at 73°F is 235 psi for saddle sizes 2" - 4", 200 psi for 6" saddles & 150 psi for 8".

### SEE PRODUCT INSTALLATION INSTRUCTION FOR DETAILS

#### COMPONENTS

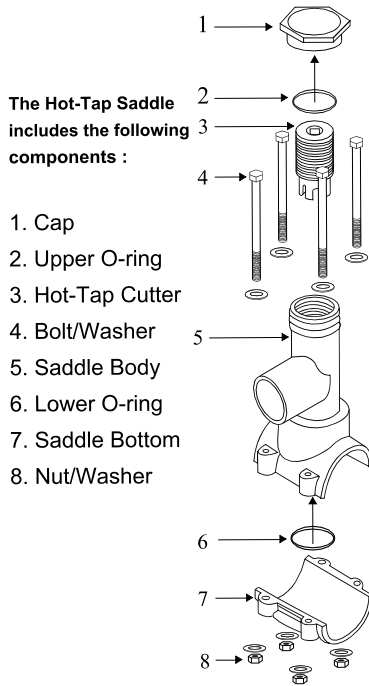

#### STEP 1 Assemble on Pipe

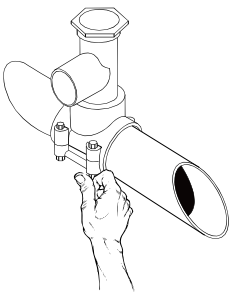

#### STEP 2 Torque to Specifications

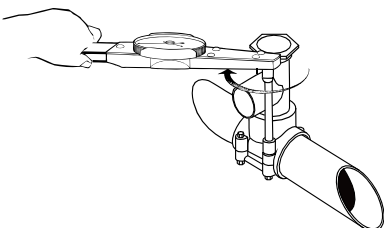

#### STEP 3 Cement Branch Take-off

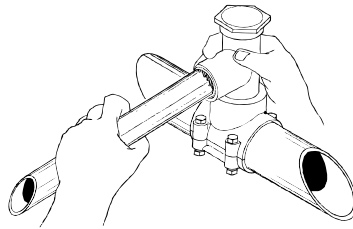

Allow joint to cure.

#### STEP 4 Remove Cap

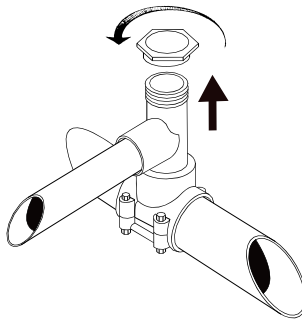

#### STEP 5 Tap to Required Depth

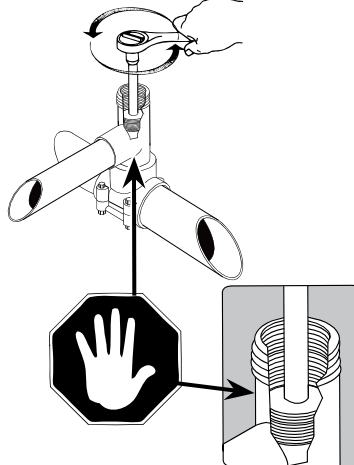

#### STEP 6 Back-off Cutter to Top to Open Flow

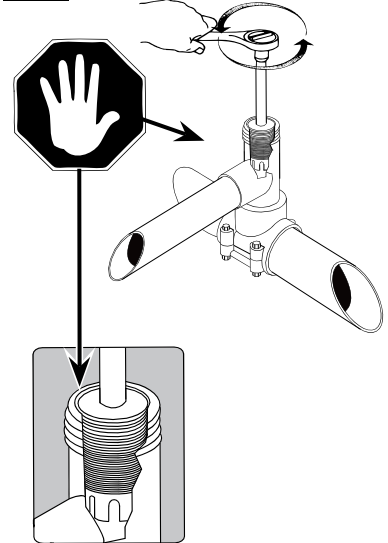

#### STEP 7 Reinstall Opening Sealed Cap

