



FlameGuard® Technical

FlameGuard® QuickTorque™ SR Gasket Sealed, Special Reinforced Sprinkler Head Adapter with Metal Threads

QuickTorque™

The One Head Adapter That Has It ALL!



Spears® New FlameGuard® QuickTorque™ CPVC Sprinkler Head Adapter uses a combination of high-strength materials to provide the most reliable, worry-free adapter in the industry:

CPVC Body for Unsurpassed Corrosion Resistance
High grade EPDM Gasket for Reliable Sealing
Metal Thread & Exterior Reinforcement for Superior Strength

The thread design and gasket seal eliminate radial stress found in tapered thread joint make up, the gasket compresses to allow sprinkler frame alignment without over tightening.

4235-101GMR 3/4"x1/2"
4235-130GMR 1"x1/2"

- ✓ Metal Thread Eliminates Cross Threading
- ✓ Requires NO Thread Sealant
- ✓ High Grade EPDM Compression Gasket Allows Quick, Easy Head Alignment
- ✓ Easiest Installation, Finger Tight Plus 1-Turn Then Align Sprinkler Head!
- ✓ NSF® Certified Lead-Free for Use in Potable Water Systems - Suitable for Use in Multi-purpose Systems

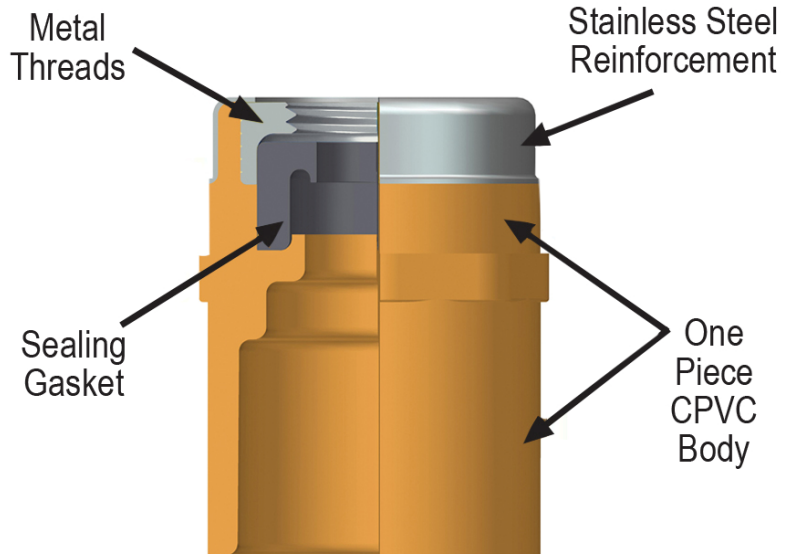

*Progressive Products From Spears®
Innovation & Technology*

QuickTorque™ Female Sprinkler Head Adapter - Gasket Sealed Metal Thread Style.

FlameGuard® QuickTorque™ SR Gasket Sealed, Special Reinforced Sprinkler Head Adapter with Metal Threads



STEP 1



DO NOT USE THREAD SEALANT

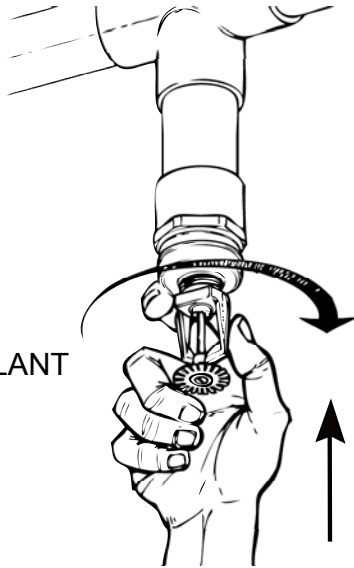
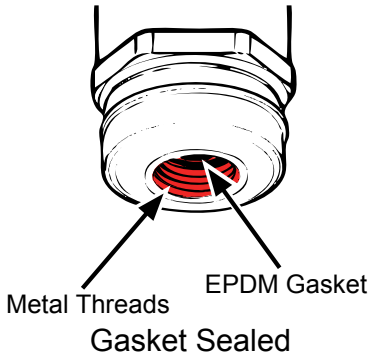

Hand Tighten Only

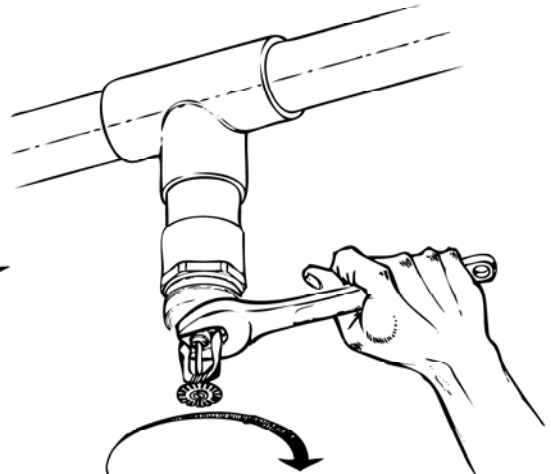

Tighten One Additional Turn Using Wrench

STEP 2

Align Sprinkler Head Horizontally

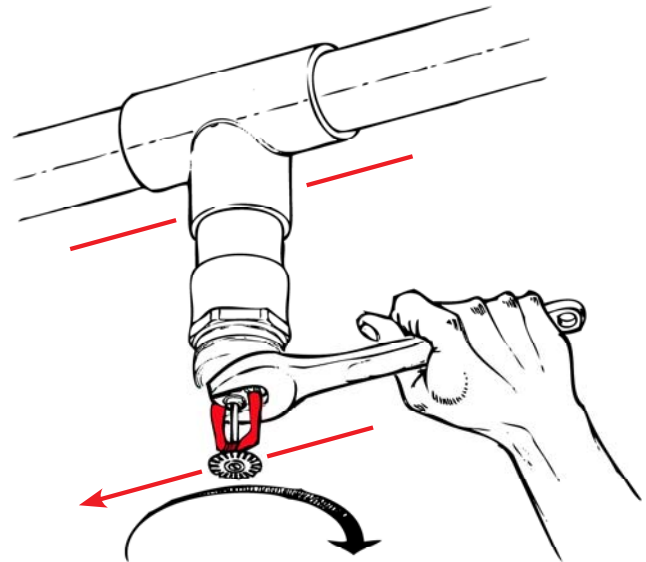
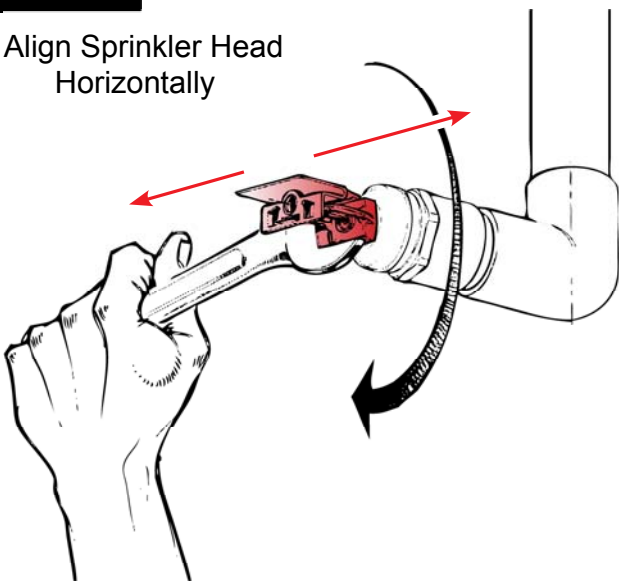

Align Sprinkler Head Horizontally