



LabWaste® Product
1-Gallon LabWaste® Dilution Traps

LabWaste® 1-Gallon CPVC Dilution Traps

Provides chemical dilution from water rinse during use. Designed for under-sink installations as a trap. CPVC construction with Glass or PP Jar type tank.

Nominal US Gallons	Inlet & Outlet Size (in.)	Inlet	Outlet	CPVC Tank Part Glass Jar Tank No.	Prod Code
1	1-1/2	Socket	Socket	T4001G1612 443.47	169

Nominal US Gallons	Inlet & Outlet Size (in.)	Inlet	Outlet	CPVC Tank Part Polypropylene Jar Tank No.	Prod Code
1	1-1/2	Socket	Socket	T4001P1612 319.29	169



Note: Slip connections are for sink drain tailpiece.

Dimensions

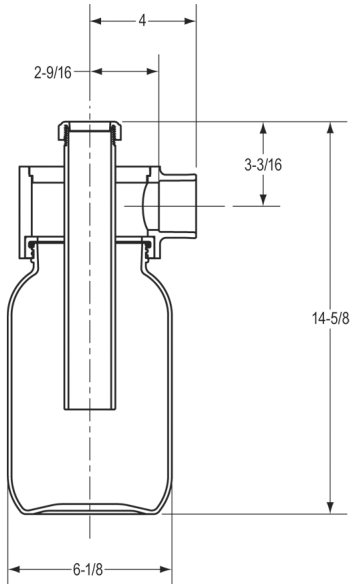

Glass

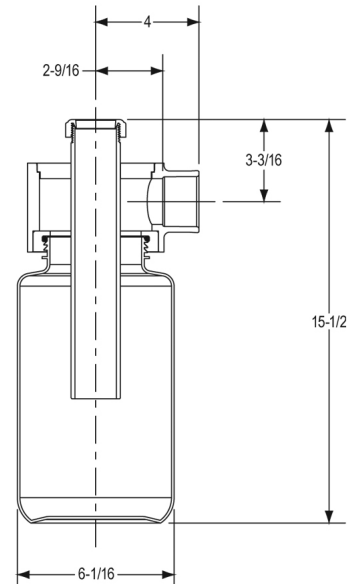

Polypropylene